

4 cylinders in line 59 HP (43.4 kW) 3000 rpm

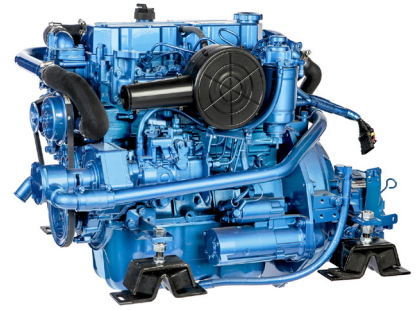

Technical Specifications

Base	Mitsubishi
Type	Diesel 4 Stroke Cycle
Number of Cylinders	4 in line
Intake System	Atmospheric
Bore x Stroke	88 mm x 95 mm (3,46 in x 3,74 in)
Total Displacement	2311 cc
Compression Ratio	22:1
Intermittent Power (ISO3046/1)	59 HP (43.4 kW)
Continuous Power	53.2 HP (39.1 kW)
Rated RPM	3000
Combustion System	Indirect mechanical injection
Starter Motor	12 V (2 kW)
Alternator	95 A 12 V
Engine Max Installation Angle	Max static angle 12° (+ 3° in operation)
Direction of Rotation (Crankshaft)	Anti Clockwise
Cooling System	Sea water cooled heat exchanger
Dry Weight (bobtail)	217.4 Kg (479 Lbs)
Water Hose (Inside Diameter)	32 mm (1,26 in)
Fuel Feed Hose (Inside Diameter)	8 mm (0,31 in)
Fuel Return Hose (Inside Diameter)	6 mm (0,24 in)
Exhaust hose (inside Diameter)	60 mm (2,36 in)
Certifications	EU: RCD I (Directive 94/25/EC), SOLAS

Dimensions

MINI-62 TMC-60

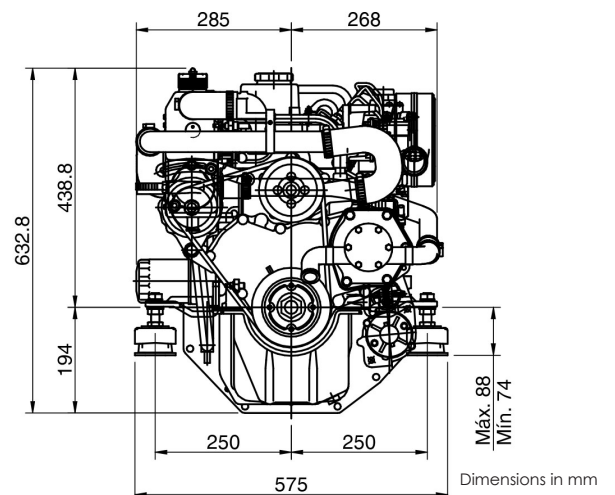
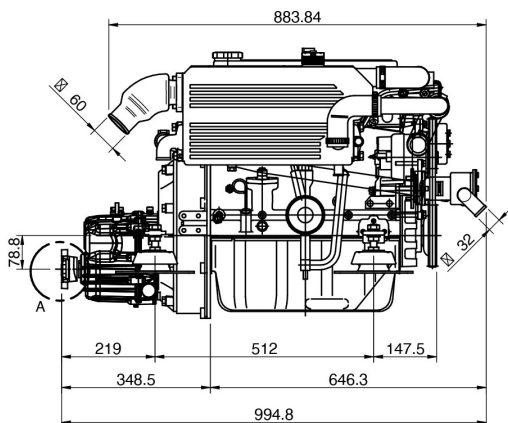

Dimensions in mm

Performance Curves

Crankshaft torque

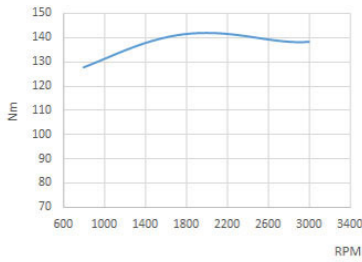

Power (ISO 3046/1)

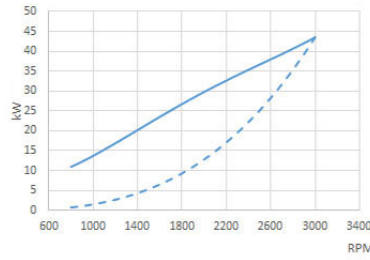

Fuel Consumption

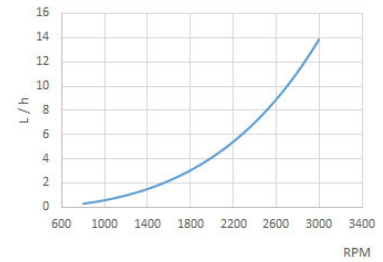

Engine Power

Propeller Power

Panels

SVT 20 Standard



- Tachometer including hour meter
- Coolant Temperature Gauge
- Pre-heating Pilot Light
- Low Battery Alarm
- High Temperature Alarm
- Low Oil Pressure Alarm
- 5 Positions Key
- Dimensions: 205 x 155 mm



SVT 30 Optional

- Tachometer including hour meter
- Coolant Temperature Gauge
- Pre-heating Pilot Light
- Low Battery Alarm
- High Temperature Alarm
- Low Oil Pressure Alarm
- 5 Positions Key
- Oil Pressure Gauge
- Voltmeter
- Dimensions: 255 x 160 mm

Accessories

Scope of Supply

- Packaging
- Instrument Panel SVT 20
- Extension Harness 3 m
- Silentblocks
- Sump Drain pump
- Owner's Manual

Optional Equipment & Kits

- We have a wide range of available accessories and kits.
- Our technical department will calculate the propeller to optimize your engine
- For additional information access our website

Gearbox

Model	Type	Down Angle	Reduction Ratio (Light Duty)	Reduction Ratio (Cont. Duty)	Engine Weight with Gearbox
SP60	Sail Drive	0°	2.14:1	-	269 Kg (593 Lbs)
TM-345	Hydraulic	0°	2.00:1 - 1.54:1 - 2.47:1	2.00:1 - 1.54:1 - 2.47:1	250 Kg (551 Lbs)
TM-345A	Hydraulic	8°	2.47:1 - 2.00:1 - 1.54:1	2.47:1 - 2.00:1 - 1.54:1	250 Kg (551 Lbs)
TM-93	Hydraulic	0°	2.09:1 - 2.77:1 - 2.40:1	2.09:1 - 2.77:1 - 2.40:1	284 Kg (626 Lbs)
TM-93A	Hydraulic	8°	2.40:1 - 2.09:1	2.40:1 - 2.09:1	284 Kg (626 Lbs)
TMC-260	Mechanical	0°	2.47:1 - 2.00:1	2.47:1 - 2.00:1	237 Kg (522 Lbs)
TMC-60A	Mechanical	7°	-	-	234 Kg (516 Lbs)
TMC-60P	Mechanical	0°	2:1	-	234 Kg (516 Lbs)
ZF 15 MIV	V-Drive M.	15°	2.134:1	-	239 Kg (527 Lbs)

Authorized Dealer



solediesel.com - info@solediesel.com

Detailed drawings, brochures and manuals are available on the web. © 2017, Solé Diesel. All rights reserved. Technical specifications, data and presentation are subjected to variations, changes and updates without prior notice, and without any obligation or liability whatsoever. Text and illustrations are not binding.

